

# **RYDEEN**<sup>®</sup>

find your road

■ PSR4000D



■ PSK4



■ PSK4 Flush



■ SPK003



■ LED003











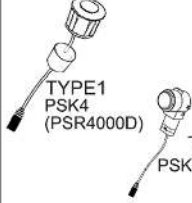

***PSR4000D***  
***PSK4***  
***PSK4 Flush***  
***SPK003***  
***LED003***

**Owner's Manual**  
**Digital Parking Sensor Systems**  
**V1.0**

## ⚠ WARNINGS ⚠

- **THE FOLLOWING INSTRUCTIONS ARE INTENDED FOR AUTHORIZED RYDEEN MOBILE INSTALLERS ONLY.**
- Dropping any components in the system or subjecting it to excessive shock and vibrations as this may cause it to malfunction and is not covered by warranty.
- **The Control Box of the Parking Sensor System IS NOT WATERPROOF.** Avoid exposing it to rain or other forms of excessive moisture.
- **Water damage is not covered under the warranty.**
- **CAN BUS Vehicles:** There is NO NEED TO CUT AN ORIGINAL VEHICLE WIRE YOU MUST SPLICE WIRE ONLY AND OBTAIN POSITIVE POWER (+12V).
- **MUST CHECK BEHIND BUMPER FOR ANY METAL BRACKETS OR INTERNAL BRACES BEFORE DRILLING**
- The Parking Sensor Systems are used for the rear placement only, these are not recommended for front mounted bumpers.
- **The use of Rydeen Parking Sensor system should never replace normal operational and safety precautions needed for reversing a vehicle. Caution should always be taken in ANY vehicle operation.**

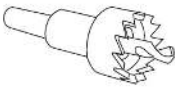
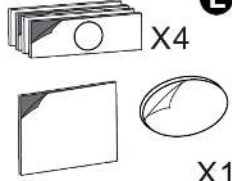
## 1. Kit Contents

 <b>A</b> X1	 TYPE1 PSK4 (PSR4000D) X4 TYPE2 PSK4 Flush X4 <b>B</b>	 <b>C</b> PSK4 Flush X4	 SPK003 (PSR4000D) X1 <b>D</b>	 LED003 (PSR4000D) X1 <b>E</b>
 EXTENSION CABLES X4 <b>F</b>	 Power Wire X1 <b>G</b>	 Display Wire X1 <b>H</b>	 Sensor Wire X4 <b>I</b>	 Button X1 <b>J</b>
 X1 <b>K</b>	 X4 X1 <b>L</b>	 Paint Mask X1 <b>M</b>		

# 2. Technical Information

## 1) Basic Specification

Specifications	
Display	Direction indicator (LED display is included)
Detecting distance	0 - 8.0 feet for flat surfaces; 0 - 6.0 feet for human or uneven surfaces
Sensors	Universal sensors. Rear sensors instantly turn on with reverse gear selection; Front sensors instantly turn on with brake selection.
Operating conditions	
Nominal Voltage	DC 12V
Working Voltage range	DC 9V~16V
Working current	20mA ~ 300m A
Working Temp.	-20°C ~ + 80°C
Ultrasonic frequency	40 KHz
Others	
Sensor	Waterproof IP67-69
Installation method	Drilling
Cable length	Sensor Cable: 2300mm+4000mm+200mm=6500mm, with extension cables.

## 2) Wire Connection Diagram

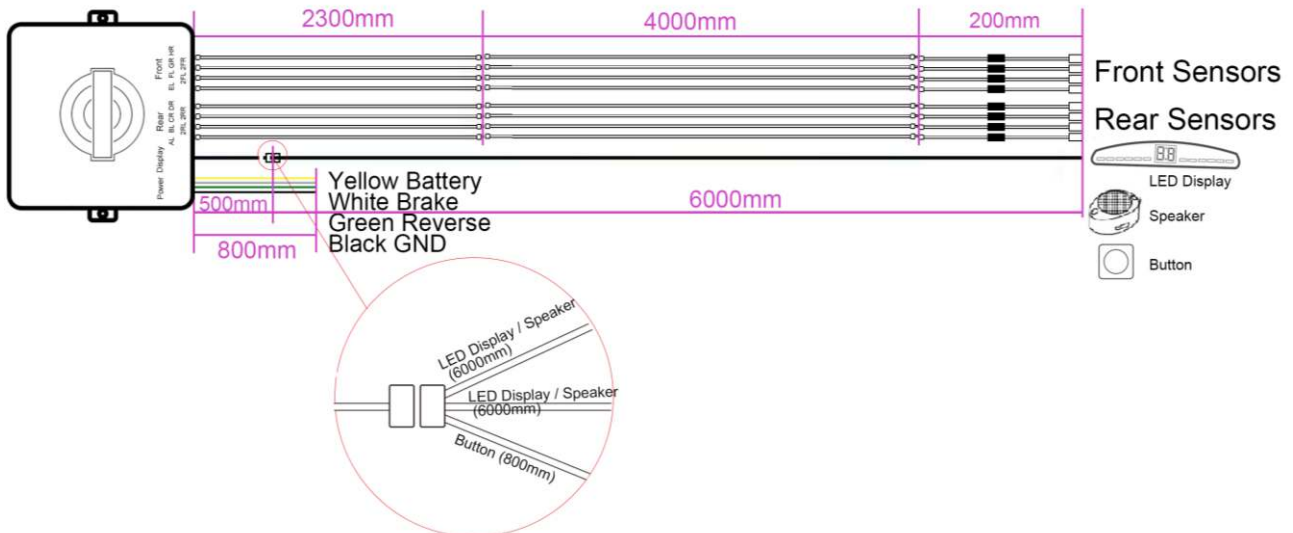

## 3) LED Display and Speaker Alarm Conditions

Rear sensors (AL. BL. CR. DR. / 2RL. 2RR): Accurate display of distance and the correct sound tips, display: feet.				
Detection distance				
NO.	Distance (unit: feet)	Level definition	Display	Alarming sound
1	5.0 – 8.0	Safe	5.0 - 8.0	NO
2	3.0 < — < 5.0	Safe	3.0 - 5.0	Bi...Bi...Bi...
3	1.0 < — < 3.0	Warning	1.0 - 3.0	Bi.Bi.Bi.
4	≤ 1.0	Danger	0 - 1.0	Biiii-----
Front sensors (EL.FL.GR.HR/2FL. 2FR): Accurate display of distance and the correct sound tips, display: feet.				
Detection distance				
NO.	Distance (unit: feet)	Level definition	Display	Alarming sound
1	3.0 <	Safe	NO	NO
2	2.0 < — < 3.0	Safe	2.0 - 3.0	Bi...Bi...Bi...
3	1.0 < — < 2.0	Warning	1.0 - 2.0	Bi.Bi.Bi.
4	≤ 1.0	Danger	0 - 1.0	Biiii-----

## 2. Painting the Sensors

### 1) Preparation

#### **For PSR4000D/PSK4**

Remove the plastic rings (**silicon rubber is not removable, do not attempt to remove**)



#### **For PSK4 Flush**

Make sure the silicon rubber rings are not installed around the sensor head

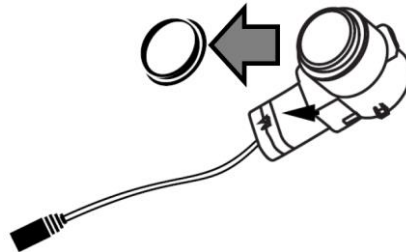

2) Sand the surface of sensors with a fine sandpaper (1000 or 1200 grit) for better paint adhesion. Clean the sensor well to be free from sanding dust.

3) Place the sensors inside the paint mask box (provided).

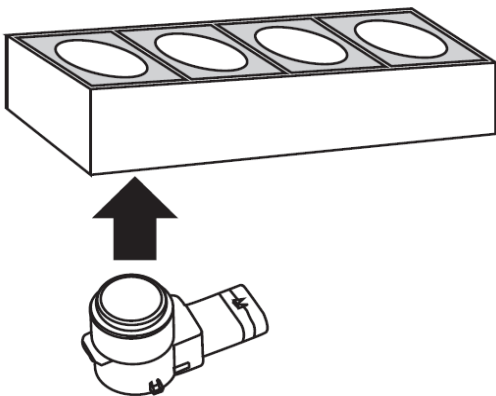

4) Spray and paint

Apply a thin coat of paint. Let it dry then paint again for better paint coating coverage.

#### **For PSR4000D/PSK4**

Paint the plastic rings together with the sensor heads.

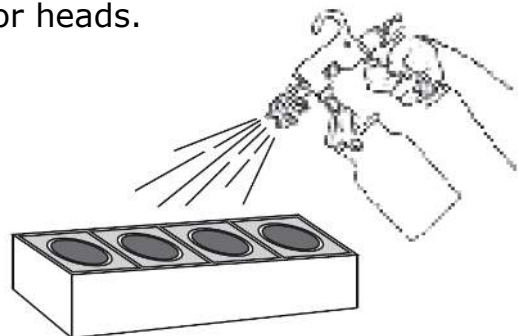

### 5) **For PSK4 Flush**

Depending on the vehicle body color, place white silicon rubber rings for a lighter color vehicle, place black rings for a dark color vehicle.

# 3. Systems Overview

For Passenger Cars

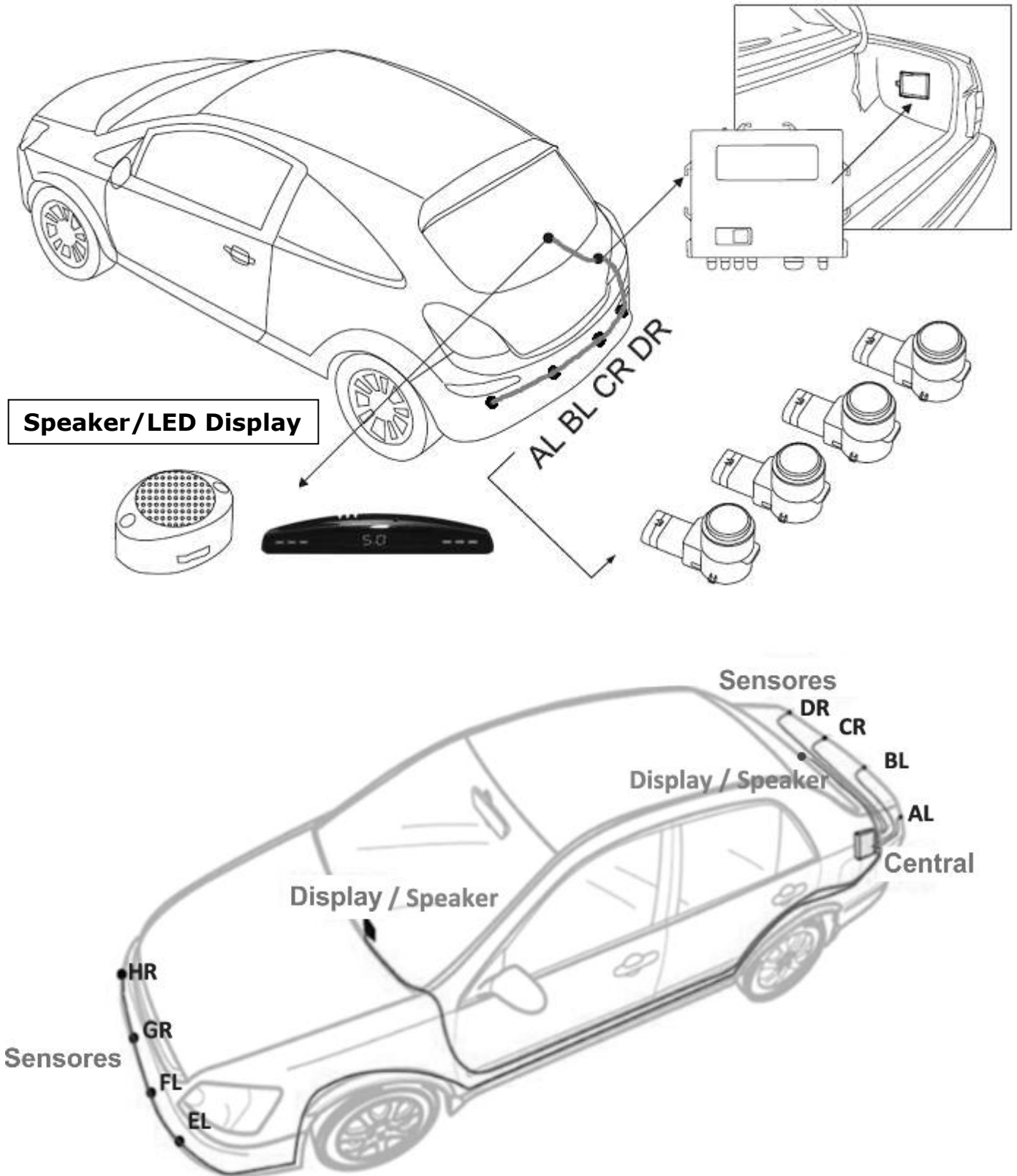

## For Trucks

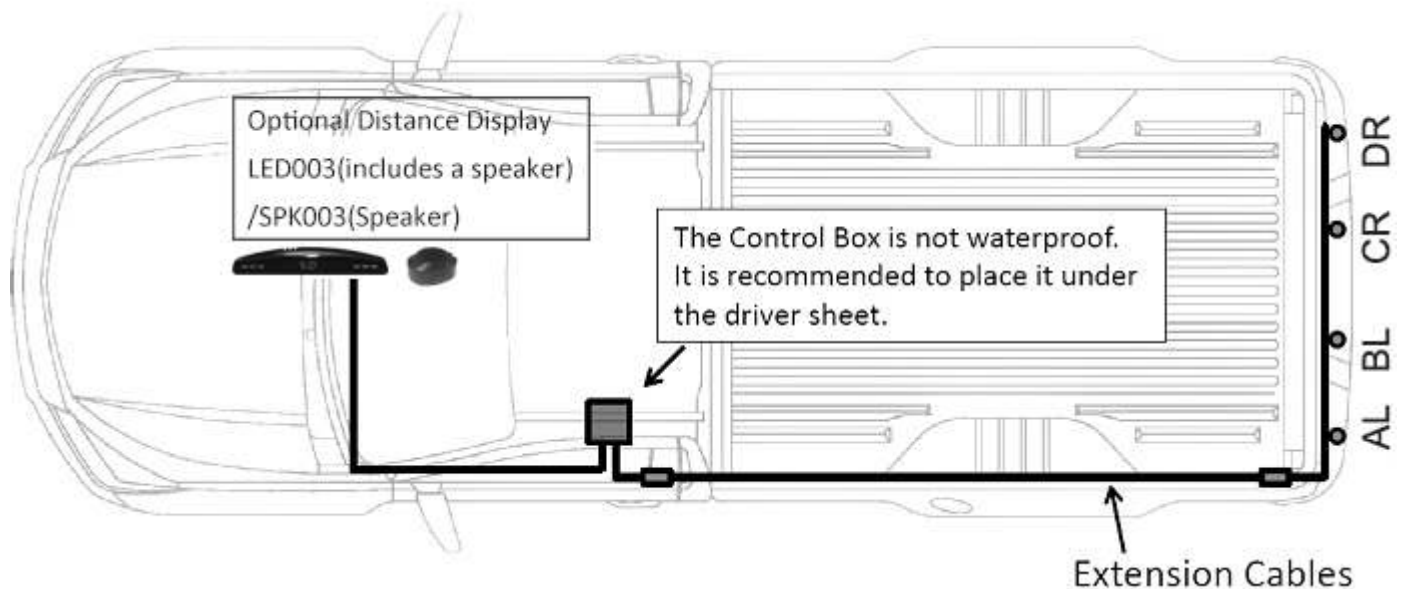

## There are 8 LED Display Options

### LED DISPLAY OPTIONS

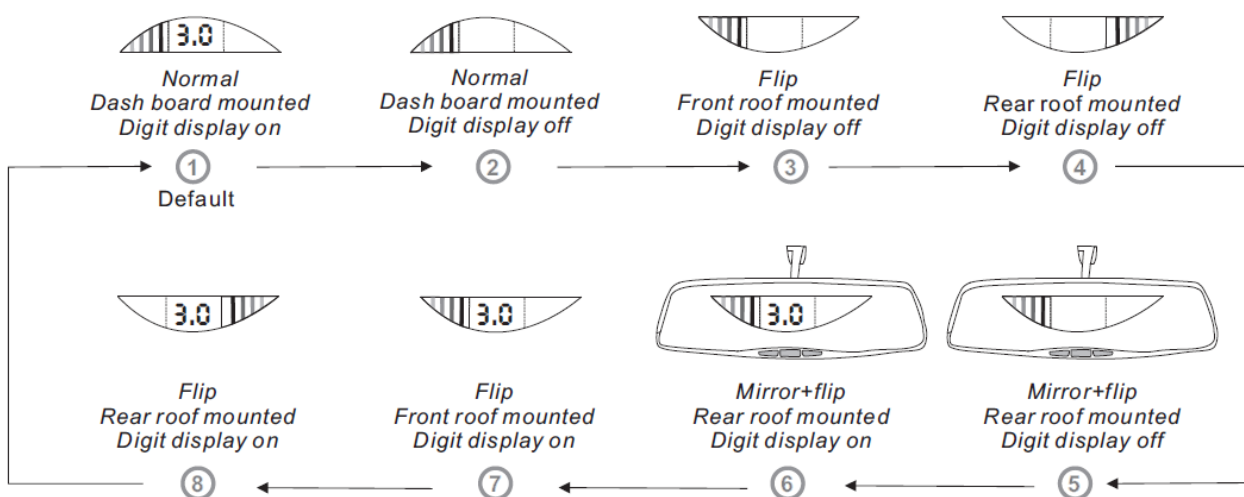

\*The object exists left-rear area.\*

**Place the speaker and control box inside a vehicle. Avoid from water damages. The LED built-in speaker/speaker sound will indicate the distance between the sensors and the object. Shorter pitch tone sound indicates getting closer to objects.**

## 4. Installation

- 1) The proper placement of the sensors is important both for appearance and for the proper operation of the unit. Sensors should be mounted at 90° angles to the ground. It is important to avoid obstructions caused by bumper shape.
- 2) Measure the height on a bumper for proper installation locations.

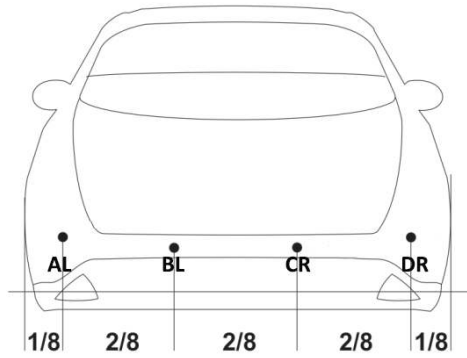

**For Rear: 4 sensors installation**

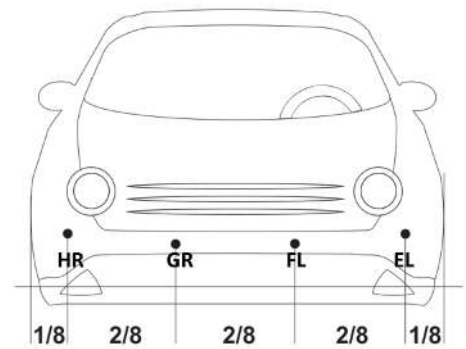

**For Front: 4 sensors installation**

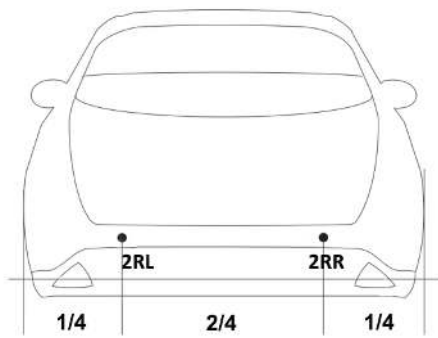

**For Rear: 2 sensors installation**

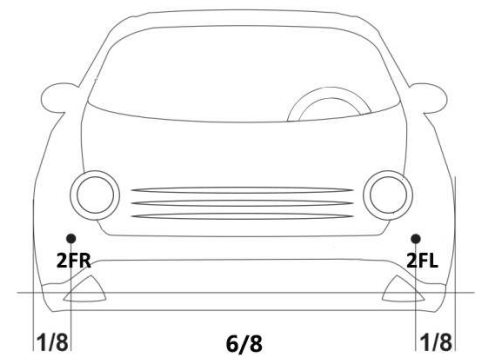

**For Front: 2 sensors installation**

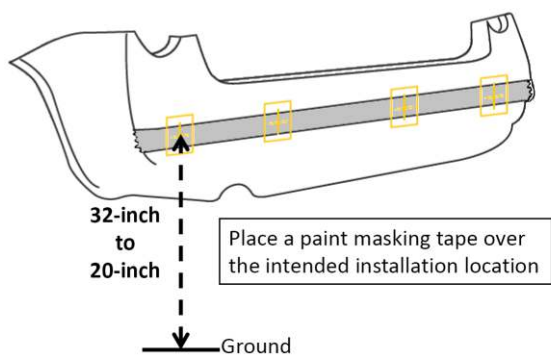

3) Generally, it is the best to mount the sensors as high as possible in the bumper. Use paint masking tape and mark the location as above diagram for the proper spacing of the sensors.

**Important!**  
**MUST CHECK BEHIND THE BUMPER FOR ANY METAL BRACKETS OR INTERNAL BRACES BEFORE DRILLING**

- 4) Three installation options:
- a. 4 digital parking sensors for rear. (PSR4000D)
  - b. 2 digital parking sensors for front, 2 for rear. (PSR4000D)
  - c. 4 digital parking sensors for rear, 4 for front. (PSR4000D and PSK4 / PSK4 Flush)

5) Also be sure that the bumper surface and the sensors will fit at 90° to the ground. Make sure the hole surface is clean and start cutting the bumper surface in counter clockwise direction (A) first to prevent from paint to chip, then drill the hole in clockwise direction (B).

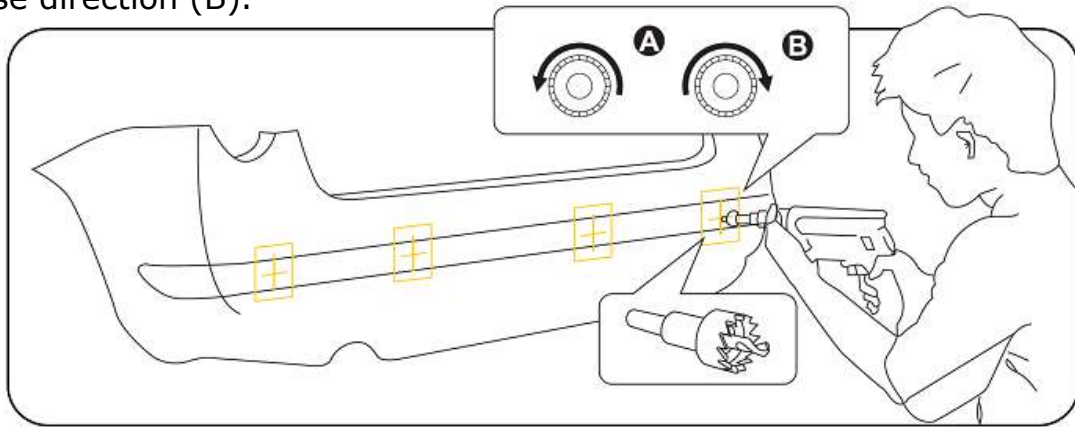

**PSR4000D/PSK4 sensors MUST be installed from outside of the bumper. Please check the direction dot (WHITE) and make sure of the correct orientation.**

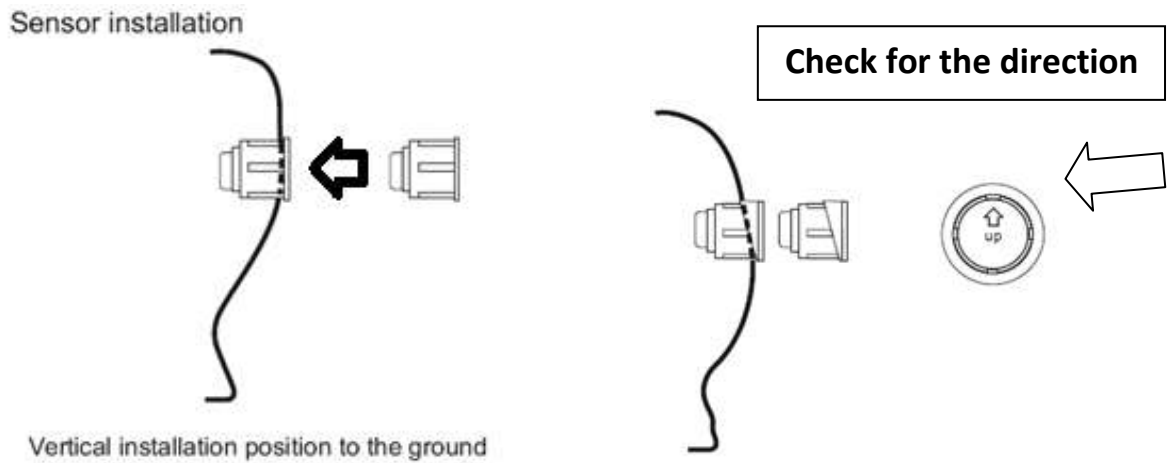

**PSK4 Flush sensors MUST be installed inside the bumper plastic skin and only the sensor head to exposed to outside. Bumper removal is required for this installation.**

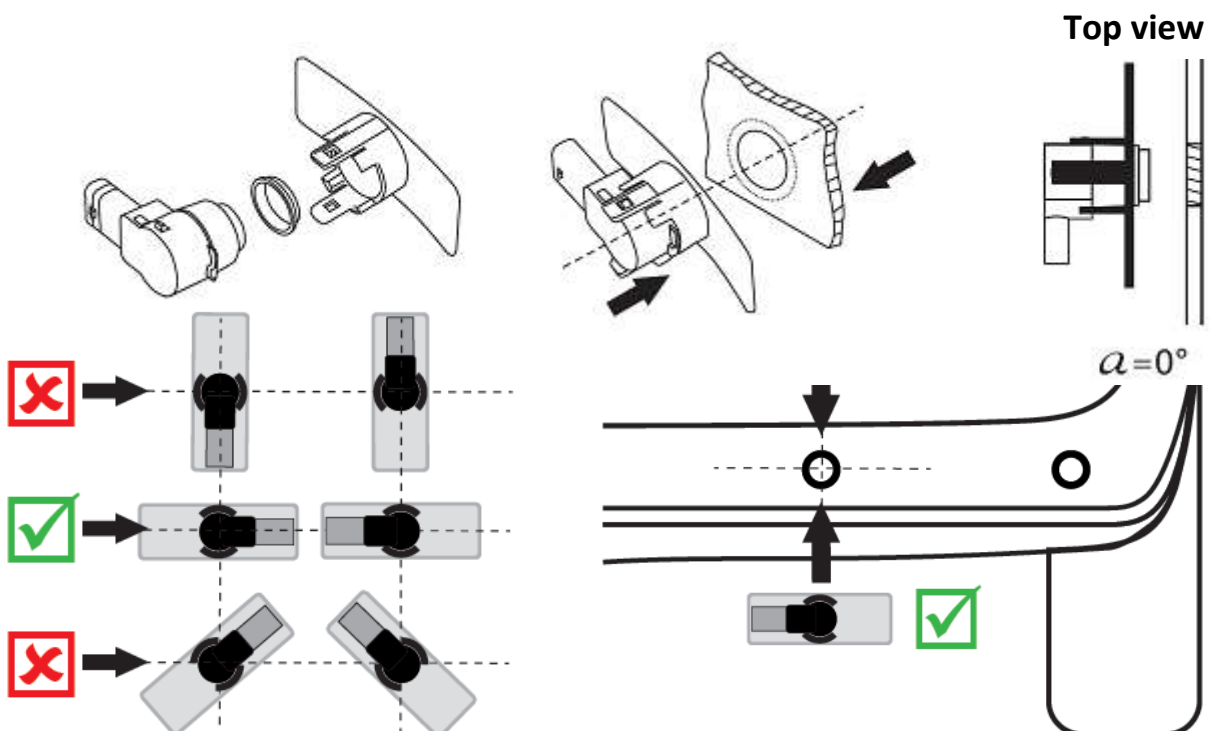



6) It is important not to drill the hole larger than the measurement indicated.

**MUST use the hole saw provided.**

**6) Route the sensor wires through the bumper to a suitable location in the vehicle trunk or rear hatch. Connect the main control unit RED wire to a positive charge wire of the vehicle back-up light. Connect the main control unit BLACK wire to a stable ground.**

7) After routing and attaching the cables, use an offal (small block of wood, etc) to press the sensors into place. **NEVER push the sensor heads (center portion) to push into the bumper.**

### Important!

- Do not use the negative charge wire of the vehicle back-up light for ground. Some vehicles have a “check bulb” feature that makes that wire not a true ground.
- The system may not detect a small and round pole (such as a fire hydrant or light pole, etc).
- When the vehicle approaches a rising slope, the slope may not be detected, as most of the signal will be reflected up and not back at the vehicle.

## 5. Detecting Range

### Normal Detecting Range

The sensors’ detection range is as following. They can detect up to 8-feet.

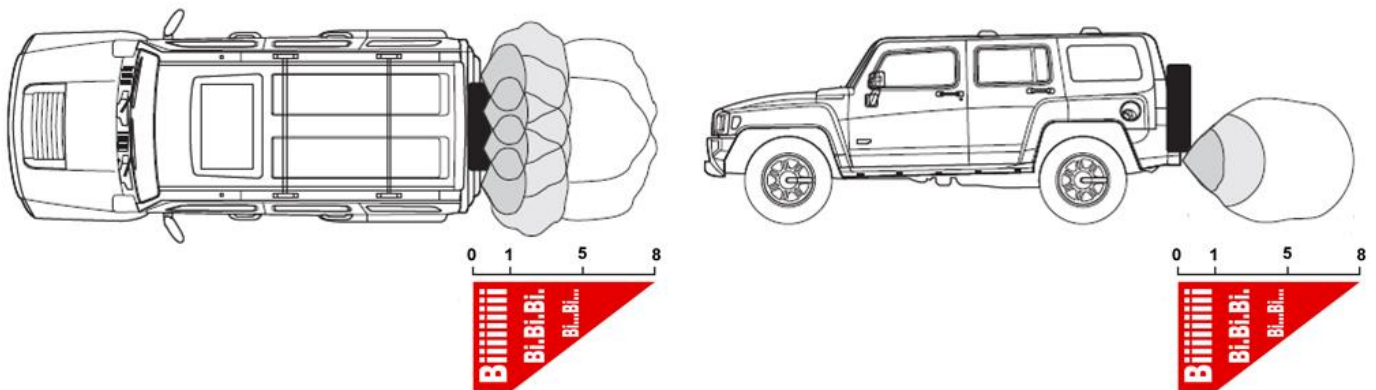

### Programming the Control Box with a Spare Tire or Bicycle in Back of Vehicle

In case the vehicle carrying a spare tire or a bicycle, the control unit can be pre-adjusted to indicate the alternative STOP position. There are five adjustment levels (0.5 feet for each level): 0.0(level 0 as Default) =>1.0(level 1, -0.5 feet) =>2.0(level 2, -1 feet) =>3.0(level 3, -1.5 feet) =>4.0(level 4, -2 feet) =>5.0(level 5, OFF) => 0.0(level 0 as Default). The button is removable and the setting can be kept. Make sure to TEST before the usage (using at least 3X3-feet size cardboard) in order to avoid accidents.

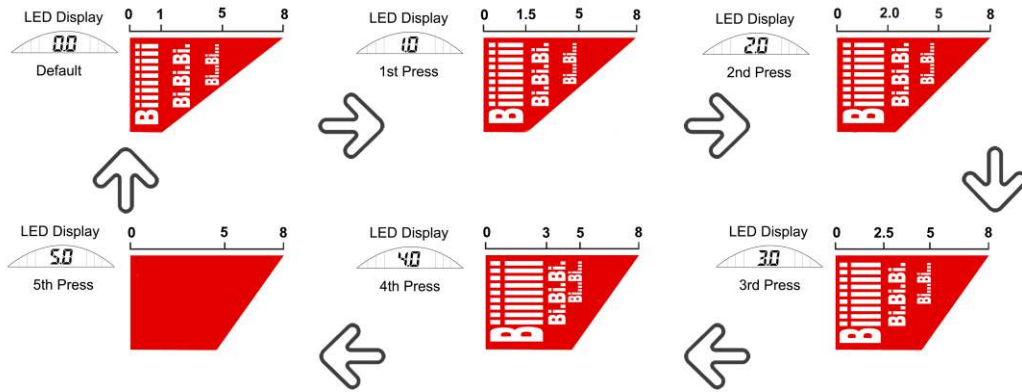
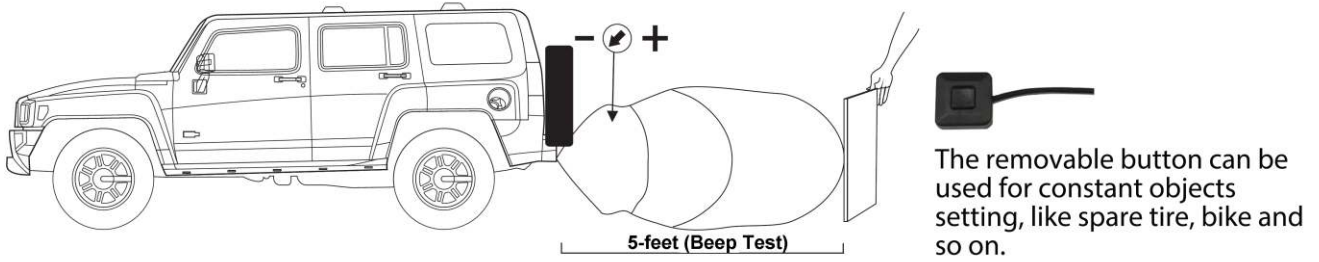

## 6. Technical Support Contact Info

If you have other questions about the RYDEEN Parking Sensor Products, please contact your retailer or Technical Support:

- Telephone: **1-877-777-8811 (within USA only)**
- Email: **tech1@rydeenmobile.com**
- Web Address: **www.rydeenmobile.com**
- Tech Forum: <http://rydeen.forumotion.com/>

# One Year Limited Warranty

Rydeen North America Inc. (a manufacturer of "RYDEEN" products) warrants this product (Parking Sensor Systems) only to the original purchaser as described by the following:

## Warranty Period

Rydeen warrants this product for a period of one (1) year from the original purchase date.

## Warranty Coverage

This warranty covers all defects in material and workmanship except as specified below.

1. Installation by anyone other than an authorized RYDEEN retailer voids the warranty.
2. Any products distributed outside of the USA by Rydeen North America Inc. (RYDEEN) or which is not purchased in the USA or Canada unless the product is purchased through the USA Military Exchange Service.
3. Any product(s) which are purchased from an unauthorized retailer (in store or online).
4. Any products in which the serial number label or the model number label are removed, torn, modified or replicated.
5. Any damage defects or malfunctions resulting from any of following:
  - a) When defect occurs during shipment of product (freight carrier's responsibility).
  - b) Installation or removal of product.
  - c) Accidents, act of nature, misuse, abuse, neglect, unauthorized product modification or failure to follow product owner's manual instructions.
  - d) Any repair or attempt to repair without RYDEEN authorization.
  - e) Any other cause which is not related to product defect.
  - f) Any cosmetic damages due to normal wear and tear.
  - g) Any consumable items (such as fuse or batteries).

If any problems develop with your RYDEEN products during or after the Limited Warranty Period, or if you have any questions regarding the operation or installation of the product, you should contact your RYDEEN retailer. If the problem or your question is not handled to your satisfaction, please contact Rydeen Customer Service Department at 1-877-777-8811 (within the USA only) Monday - Friday between 9:00 AM to 4:00 PM Pacific Standard Time or visit [www.rydeenmobile.com](http://www.rydeenmobile.com).



[www.rydeenmobile.com](http://www.rydeenmobile.com)

Rydeen North America Inc.  
dba Rydeen Mobile Electronics  
2701 Plaza Del Amo, Suite 705, Torrance, California 90503 USA  
Phone: 1-877-777-8811 Fax: 1-310-943-3778

Copyright © 2014 Rydeen North America Inc. All Rights Reserved.

These materials are protected by copyright law and international treaties. Any unauthorized use, reproduction or distribution of these materials, or any portion herein, will result in severe civil and criminal penalties and fines. Violators will be prosecuted to the fullest extent of the law.